

Fog light installation for 99-00

QTY Parts List:

2	Fog lights and brackets w/ bulbs
1	Wiring Harness
1	Fuse
1	Black Relay
6	U-nuts/clips
6	Screws
1	Pink 3M scotch-lok wire tap

Fog light installation in bumper:

1. Removing the bumper is not necessary; driving the car onto ramps or raising it up will ease installation. If you aren't able to install them, you can remove the wheel well splash guards.
2. Use a knife and cut the bars out from the fog light holes; you may have to file down the edges.
3. Three clips and three screws are used to hold each fog light. Place the clips on the two tabs above the fog light opening (see picture 1). The third clip goes on the bottom of the fog light (see picture 2). First place the fog light in the hole and screw in the bottom of the fog light. Then install the top screws, a magnetic screwdriver will help.

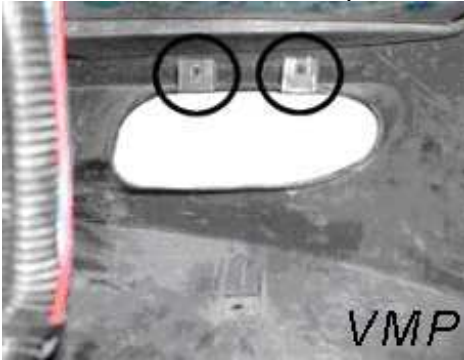

Two of the six supplied clips above the foglight hole.

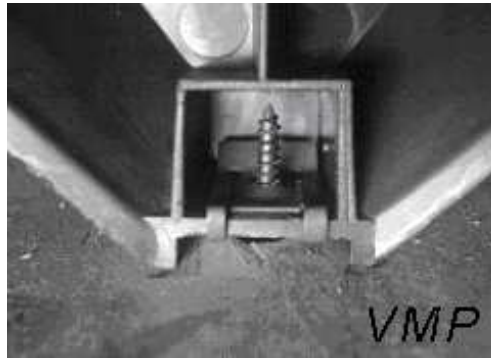

One clip and screw holds bottom of fog light to THE bumper.



Finished fog light is secure.

Wiring engine bay:

1. Connect the **orange** wire with fuse holder to +12v battery or side of the fuse box. (see picture 1 & 2). Do not install the fuse in the *fuse holder* until the installation is complete.
2. Connect short **black** wire to ground, the negative terminal of the battery or the bolt behind the headlight can be used as a ground. (see picture 3)
3. Run the short **red** driver side wire through the hole behind the headlight and down to the fog light.
4. Run the long **red** passenger side wire over the radiator through the hole behind the passenger side head light and down to the fog light.
5. Plug in each **red** wire to fog light bulb socket.
6. Ground both **black** right and left wires (these wires are attached to the fog light connectors) to nearby ground bolts. The black wires will reach the hood latch support bracket and the power steering cooler support for grounds.
7. Plug in the supplied black relay to the wiring harness; zip tie it to the side of the fuse box (there is a small hole between the battery and the fuse box) in an upright dry position.
8. See Wiring passenger compartment to wire the long **blue** wire.



Wire **orange** wire to + battery side

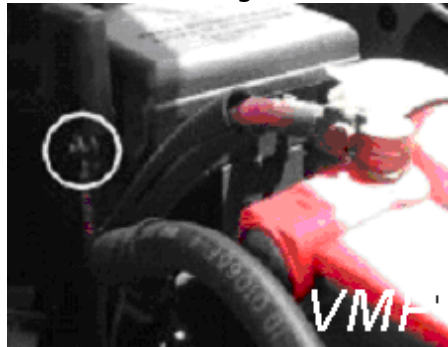

You can also wire **orange** wire to the side of the fuse box.



Wire **black** ground wire to -12v ground on the battery.

Wiring in the passenger compartment:

1. Run the blue wire attached to the relay socket through the fire wall into the passenger compartment. In automatics the hole in the fire wall is about a foot above where the steering column passes through the fire wall. On 5spds you will have to run the blue wire through an existing rubber grommet on the drivers side near the top of the firewall.
 2. Put a hole through the small rubber plug(for automatics) or grommet(for 5spds) very carefully.
 3. Run the **blue** wire through the hole.
 4. To remove the bucket under the arm rest, pull up on the two front rubber tabs.
 5. Underneath the tabs, there will be two screws you must remove. (see picture)
 6. Pull the bucket out; It's in tight, pull hard.
 7. Remove the ashtray or cup holders which are next to the parking brake. They will pop out easily.
 8. Remove the black insert where the fog light switch goes by pushing up from underneath and prying with a screw driver (wrapped in a rag).
 9. You will see two sockets far down in there, the gray socket is for the fog light switch, pull back the black plastic wrapped around the bundle of wires (connected to the gray socket).
- Note: The existing harness for the switch will be used.



Rubber grommet where **blue** wire can pass through.(automatic shown)

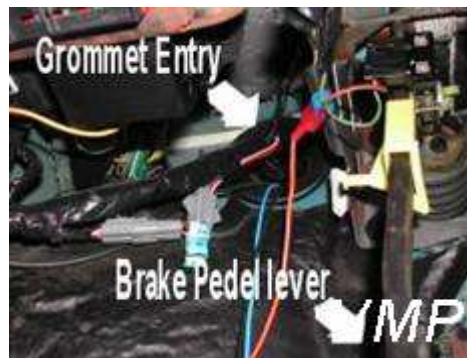

Exit through firewall into passenger compartment. (automatic shown)

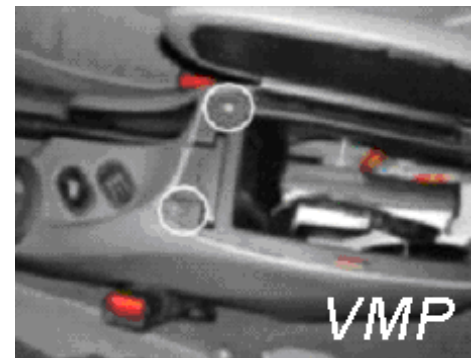

Remove rubber tabs, and then screws.

Fog light switch pin out:

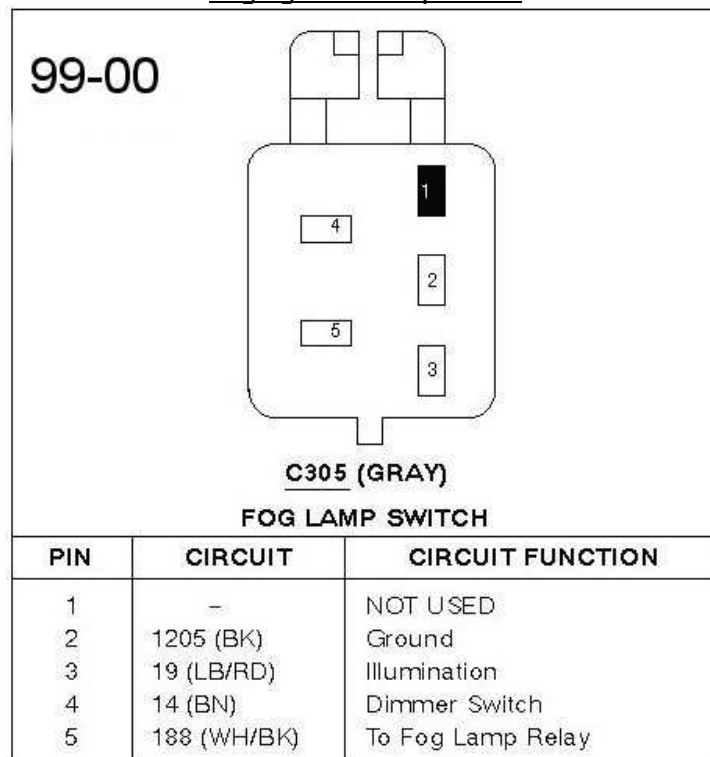

Tapping into wire:

1. Locate correct wire- pin 5, white with black stripe. (The yellow wire being tapped in picture is not correct for this year.)
2. Use supplied pink wire tap, slide white and black striped wire through the **pink** wire tap. (see picture)

3. Insert blue wire into other hole in **pink** wire tap, the hole has a dead end. (see picture)
4. Clamp down on the metal piece in the pink wire tap with pliers to splice the wires.
5. Close the **pink** wire tap firmly, make sure the both the stock wire and **blue** wire are spliced. (see picture)
6. Pull the switch socket through the fog light switch hole and plug in the switch.
7. Reinstall all components, 99-00 fog lights will work when parking lights are on.

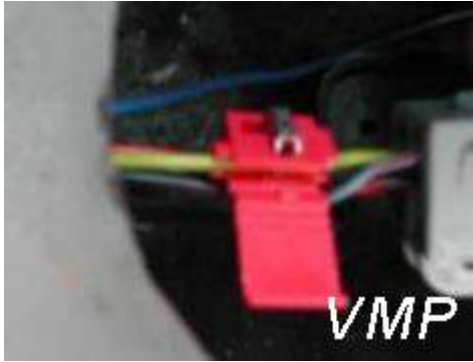

Slide the designated wire into **pink** wire tap.(94-98 car shown)

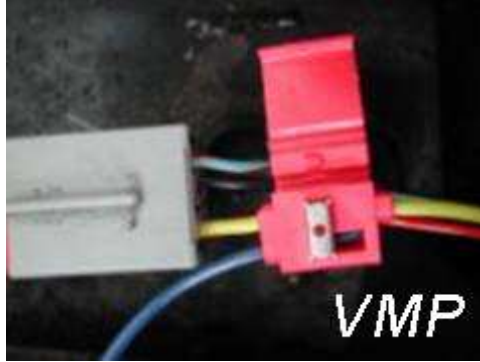

Insert **blue** wire into other hole; it has a dead end.



Crimp down metal piece with pliers and close wire tap completely.

You may wire your fog lights independently so that you will only need the key in for fog light operation. You do not need a convertible in order to do this.

Additional steps for wiring the fog lights independent of the headlights(additional parts required):

1. Locate convertible wiring harness. It has three wires; the socket looks just like the fog light harnesses' socket. See below for a picture of the convertible wiring harness.
2. Slide the middle wire of the convertible harness through the wire tap.
3. Cut the wire of pin 4 on the fog light switch harness; it is brown.
4. Insert the wire from pin 4 into the other side of the wire tap; it has a dead end.
5. Push down the metal piece in the wire tap with pliers to splice the wires.
6. Close the wire tap cover firmly and completely.
7. Reinstall all components properly.
8. The fog lights will only work when the key is in RUN or ON position.



Slide correct wire into wire tap.



Insert cut pin 4 wire from switch wiring into other hole(**Blue** wire shown)

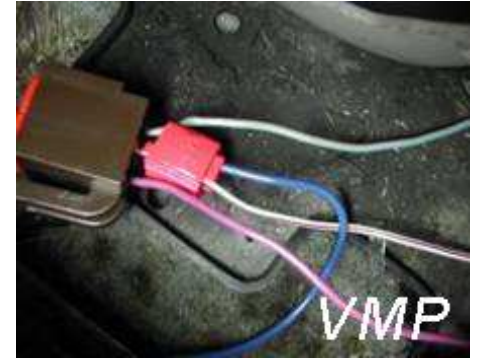

Use pliers and clamp down on metal piece; close wire tap completely.

If the wiring on your car seems different or you are having problems with installation, email us.

Sales@VMPTuning.com
www.VMPTuning.com

Removing bulbs:

1. Grasp bulb. Turn bulb very carefully counter clockwise.
 2. Slowly pull bulb outward; be very careful not to break the bulb.
- Do not touch the glass part of the bulb.